

WATER COOLED CONDENSING UNIT

Model: RWUM-B030Y-20RS



DATA SHEET

DIMENSIONS TABLE

A	882 mm
B	400 mm
C	244 mm
D	622 mm
E	117 mm
F	410 mm

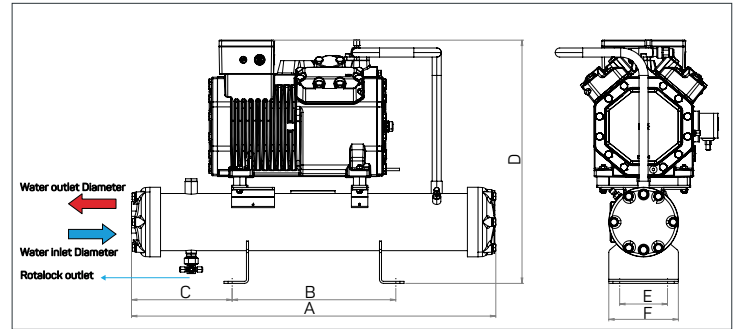

CONNECTIONS & WEIGHT

Water Inlet	G 1"
Water Outlet	G 1"
Liquid Refrigerant Outlet	1/2"
Bolt Size	M12
Weight	116 kg

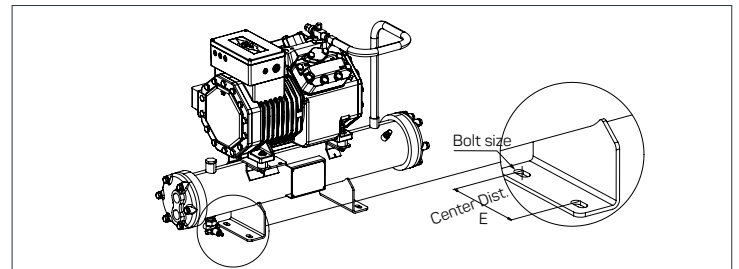

CONDENSER SPECIFICATION

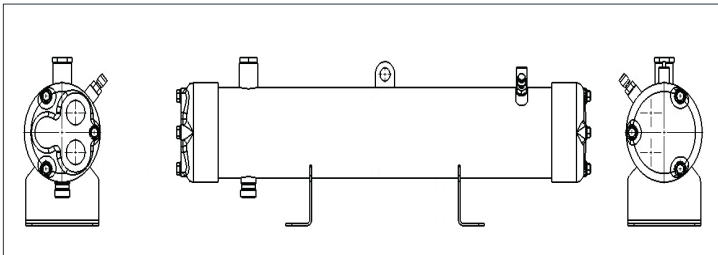

COMPRESSOR SPECIFICATION

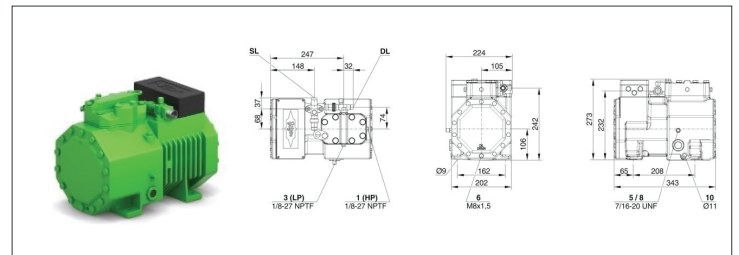

CONDENSER MODEL: 20RS

Tube Side	
Volume	2.8 L
Max Allowable Pressure	16 bar
Water flow rate	2.2 m ³ /h
Pressure drop	7.9 kPa
Shell Side	
Volume	7.5 L
Max Allowable Pressure	30 bar

BITZER COMPRESSOR MODEL: 2EES-3Y-20D

Displacement (1750 RPM 50Hz)	13.71 m ³ /h
Max. pressure (LP/HP)	19/ 32 bar
Connection suction line	22 mm – 7/8"
Connection discharge line	16 mm – 5/8"
Motor version	1
Motor voltage	360-400V Y-3-60Hz
Max. Operating current	9.5 A
Max. Power input	4.6 kW
Oil Type	BSE32 (Standard)

The **rime Water-Cooled Condensing Unit** is engineered for reliable, high-efficiency performance in commercial and industrial refrigeration applications. Designed with a compact layout and built using quality-driven components, the unit ensures stable operation, effective

heat rejection, and long-term durability under demanding conditions. Our manufacturing capabilities, reflects a commitment to precision, reliability, and building refrigeration solutions that are designed to perform and built to endure.

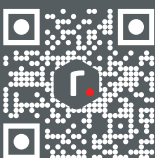

CONTACT
SALES@RIMEGROUP.COM
+971 4 4918522

RIME GROUP FZE
Plot No. S21315, South Zone JAFZA, Dubai, UAE
P.O Box 26828 | www.rimegroup.com