

WATER COOLED CONDENSING UNIT

Model: RWUB-D300Y-120R



DATA SHEET

DIMENSIONS TABLE

A	1515 mm
B	1490 mm
C	900 mm
D	200 mm

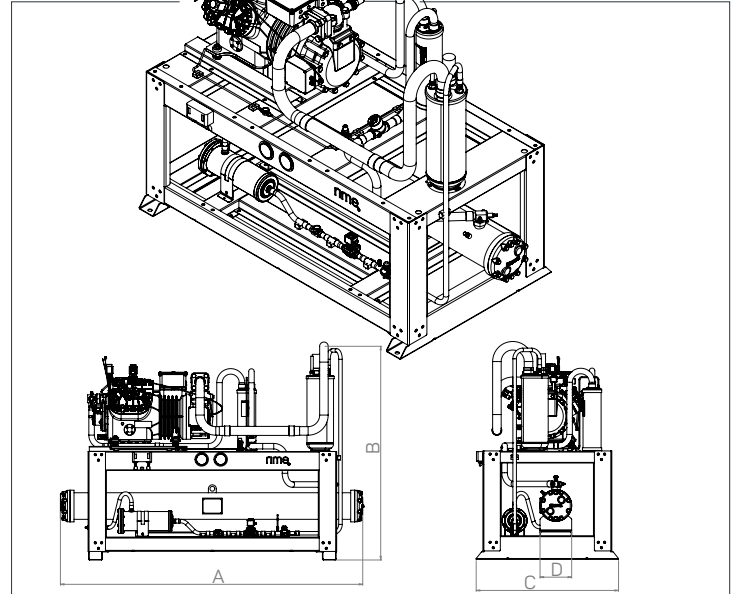

CONNECTIONS & WEIGHT

Water Inlet	G 2"
Water Outlet	G 2"
Liquid Refrigerant Outlet	7/8"
Weight	357 kg

CONDENSER SPECIFICATION



COMPRESSOR SPECIFICATION

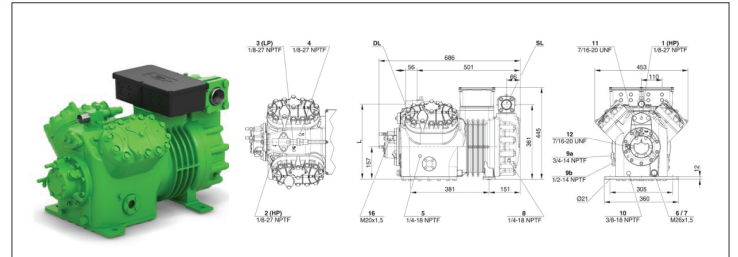

CONDENSER MODEL: 120R

Tube Side	
Volume	10 L
Max Allowable Pressure	10 bar
Water flow rate	13.1 m ³ /h
Pressure drop	10.2 kPa

BITZER COMPRESSOR MODEL: S6F-30.2Y-40P

Displacement (1450 RPM 50Hz)	73.60 / 36.90 m ³ /h
Max. pressure (LP/MP/HP)	19 / 19 / 28 bar
Connection suction line	42mm - 1 5/8"
Connection discharge line	35mm - 1 3/8"
Motor voltage	380-420V PW-3-50Hz
Max. Operating current	51.0 A
Max. Power input	31.9 kW
Oil Type	BSE32 (Standard)

Shell Side

Volume	16.1 L
Max Allowable Pressure	30 bar

The *rime Water-Cooled Condensing Unit* is engineered for reliable, high-efficiency performance in commercial and industrial refrigeration applications. Designed with a compact layout and built using quality-driven components, the unit ensures stable operation, effective

heat rejection, and long-term durability under demanding conditions. Our manufacturing capabilities, reflects a commitment to precision, reliability, and building refrigeration solutions that are designed to perform and built to endure.

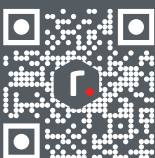

CONTACT
SALES@RIMEGROUP.COM
+971 4 4918522

RIME GROUP FZE
Plot No. S21315, South Zone JAFZA, Dubai, UAE
P.O Box 26828 | www.rimegroup.com