

WATER COOLED CONDENSING UNIT

Model: RWUL-B070Y-35R



DATA SHEET

DIMENSIONS TABLE

A	1360 mm
B	1200 mm
C	860 mm
D	170 mm

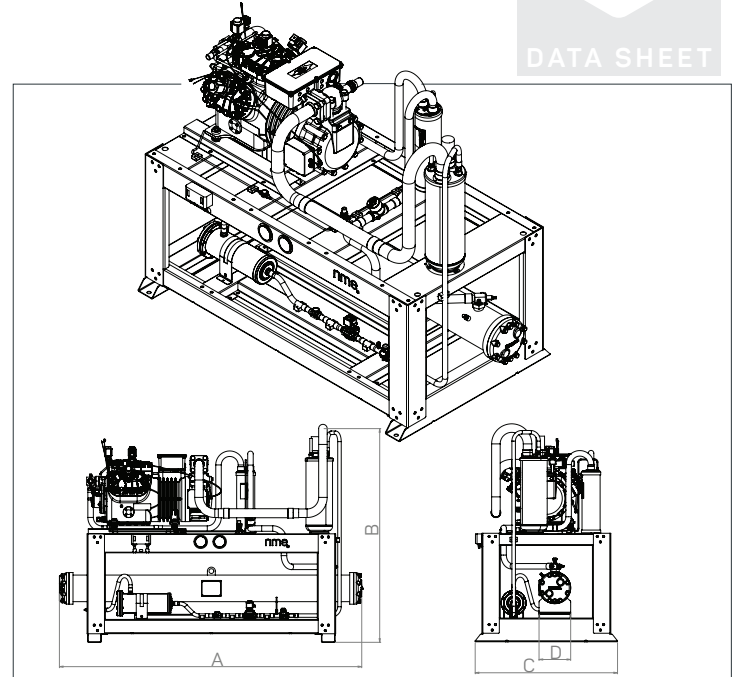

CONNECTIONS & WEIGHT

Water Inlet	G 1"
Water Outlet	G 1"
Liquid Refrigerant Outlet	1/2"
Weight	230 kg

CONDENSER SPECIFICATION



COMPRESSOR SPECIFICATION

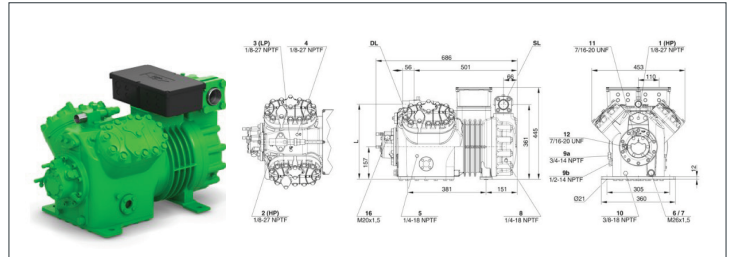

CONDENSER MODEL: 35R

Tube Side	
Volume	3.3 L
Max Allowable Pressure	10 bar
Water flow rate	3.4 m ³ /h
Pressure drop	10 kPa

BITZER COMPRESSOR MODEL: 4VE-7Y-40P

Displacement (1450 RPM 50Hz)	34.73 m ³ /h
Max. pressure (LP/HP)	19 / 32 bar
Connection suction line	28 mm – 1 1/8"
Connection discharge line	22 mm – 7/8"
Motor version	2
Motor voltage	380-420V PW-3-50Hz
Max. Operating current	16.6 A
Max. Power input	11.0 kW
Oil Type	BSE32 (Standard)

The rime Water-Cooled Condensing Unit is engineered for reliable, high-efficiency performance in commercial and industrial refrigeration applications. Designed with a compact layout and built using quality-driven components, the unit ensures stable operation, effective

heat rejection, and long-term durability under demanding conditions. Our manufacturing capabilities, reflects a commitment to precision, reliability, and building refrigeration solutions that are designed to perform and built to endure.

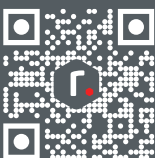

CONTACT
SALES@RIMEGROUP.COM
+971 4 4918522

RIME GROUP FZE
Plot No. S21315, South Zone JAFZA, Dubai, UAE
P.O Box 26828 | www.rimegroup.com