

WATER COOLED CONDENSING UNIT

Model: RWUM-B090Y-45R



DATA SHEET

DIMENSIONS TABLE

A	1330 mm
B	1260 mm
C	860 mm
D	200 mm

CONNECTIONS & WEIGHT

Water Inlet	G 1"
Water Outlet	G 1"
Liquid Refrigerant Outlet	5/8"
Weight	197 kg

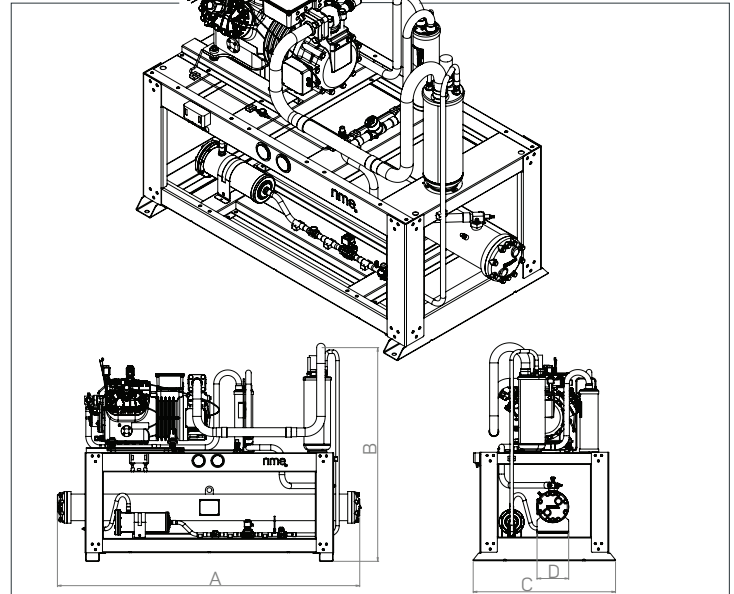

CONDENSER SPECIFICATION

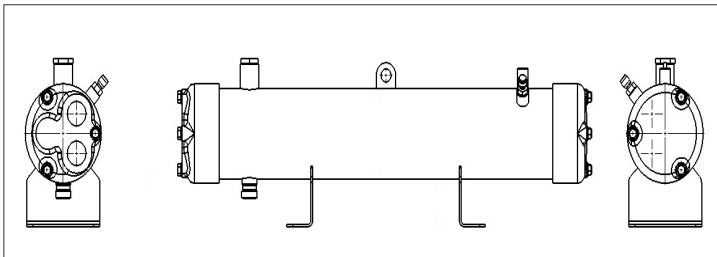

COMPRESSOR SPECIFICATION

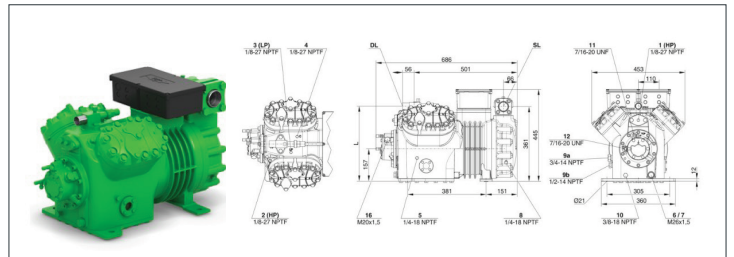

CONDENSER MODEL: 45R

Tube Side	
Volume	4.7 L
Max Allowable Pressure	10 bar
Water flow rate	4.65 m ³ /h
Pressure drop	16.9 kPa

Shell Side

Volume	9.1 L
Max Allowable Pressure	30 bar

BITZER COMPRESSOR MODEL: 4CES-9Y-40S

Displacement (1450 RPM 50Hz)	32.48 m ³ /h
Max. pressure (LP/HP)	19 / 32 bar
Connection suction line	28 mm – 1 1/8"
Connection discharge line	22 mm – 7/8"
Motor version	1
Motor voltage	380-420V Y-3-50Hz
Max. Operating current	20.2 A
Max. Power input	11.3 kW
Oil Type	BSE32 (Standard)

The *rime Water-Cooled Condensing Unit* is engineered for reliable, high-efficiency performance in commercial and industrial refrigeration applications. Designed with a compact layout and built using quality-driven components, the unit ensures stable operation, effective

heat rejection, and long-term durability under demanding conditions. Our manufacturing capabilities, reflects a commitment to precision, reliability, and building refrigeration solutions that are designed to perform and built to endure.

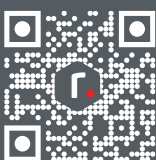

CONTACT
SALES@RIMEGROUP.COM
+971 4 4918522

RIME GROUP FZE
Plot No. S21315, South Zone JAFZA, Dubai, UAE
P.O Box 26828 | www.rimegroup.com