

WATER COOLED CONDENSING UNIT

Model: RWUM-B150Y-90R



DATA SHEET

DIMENSIONS TABLE

| | |
|---|---------|
| A | 1515 mm |
| B | 1260 mm |
| C | 900 mm |
| D | 200 mm |

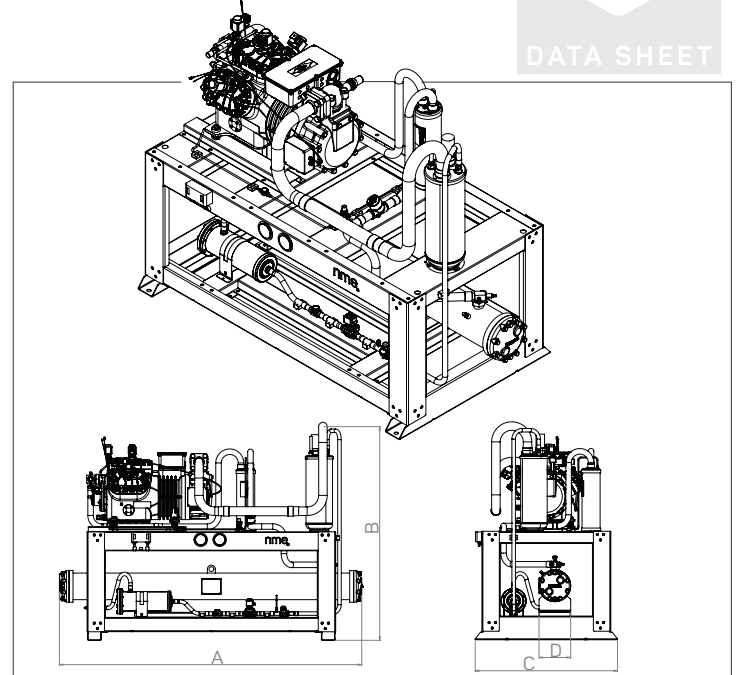

CONNECTIONS & WEIGHT

| | |
|---------------------------|--------|
| Water Inlet | G 2" |
| Water Outlet | G 2" |
| Liquid Refrigerant Outlet | 7/8" |
| Weight | 273 kg |

CONDENSER SPECIFICATION



COMPRESSOR SPECIFICATION

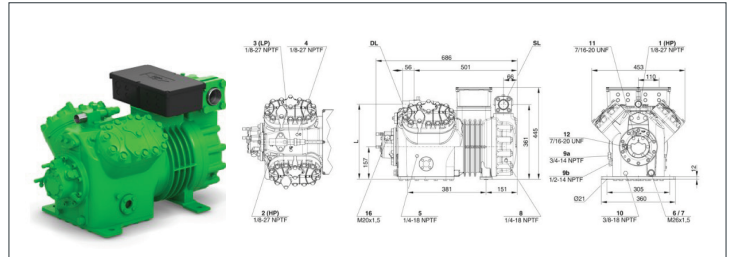

CONDENSER MODEL: 90R

| Tube Side | |
|------------------------|-----------------------|
| Volume | 7.6 L |
| Max Allowable Pressure | 10 bar |
| Water flow rate | 9.3 m ³ /h |
| Pressure drop | 8.1 kPa |

BITZER COMPRESSOR MODEL: 4PE-15Y-40P

| | |
|------------------------------|------------------------|
| Displacement (1450 RPM 50Hz) | 48.5 m ³ /h |
| Max. pressure (LP/HP) | 19 / 32 bar |
| Connection suction line | 42 mm – 1 5/8" |
| Connection discharge line | 28 mm – 1 1/8" |
| Motor version | 1 |
| Motor voltage | 380-420V PW-3-50Hz |
| Max. Operating current | 28.2 A |
| Max. Power input | 16.0 kW |
| Oil Type | BSE32 (Standard) |

Shell Side

| | |
|------------------------|--------|
| Volume | 19.3 L |
| Max Allowable Pressure | 30 bar |

The rime Water-Cooled Condensing Unit is engineered for reliable, high-efficiency performance in commercial and industrial refrigeration applications. Designed with a compact layout and built using quality-driven components, the unit ensures stable operation, effective

heat rejection, and long-term durability under demanding conditions. Our manufacturing capabilities, reflects a commitment to precision, reliability, and building refrigeration solutions that are designed to perform and built to endure.

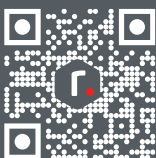

CONTACT
SALES@RIMEGROUP.COM
+971 4 4918522

RIME GROUP FZE
Plot No. S21315, South Zone JAFZA, Dubai, UAE
P.O Box 26828 | www.rimegroup.com